

日期/Date		档案员 Filing Clerk		1		2			3		4		5						6	
产品代号 Part Code	产品料号 Part NO.	重量/Weight g	线径/Wire Gauge mm ² AWG		d	D	剥线长度 Stripping Length	标识 Identification	标识图 Identification No.	No.	No.1	No.2	No.3	No.4	No.5	No.6				
CEGFH-0.37G	1010192200309	1.62g	0.14-0.37	26-22	0.90	1.8	7.5	no groove	No.1	标示图 Marked Graph										
CEGFH-0.5G	1010192200409	1.7g	0.5	20	1.15	2.6	7.5	no groove	No.1											
CEGFH-0.75G	1010192200609	1.67g	0.75	18	1.30	2.6	7.5	1 groove	No.2											
CEGFH-1.0G	1010192200809	1.66g	1.0	18	1.45	2.6	7.5	1 groove	No.3											
CEGFH-1.5G	1010192200909	1.75g	1.5	16	1.75	3.0	7.5	2 groove	No.4											
CEGFH-2.5G	1010192201009	1.78g	2.5	14	2.25	3.5	7.5	3 groove	No.5											
CEGFH-3.0G	1010192201109	1.69g	3.0	12	2.55	3.7	7.5	wide groove	No.6											
CEGFH-4.0G	1010192201209	1.74g	4.0	12	2.85	3.9	7.5	no groove	No.1											

技术参数:

- 材料: 铜合金
- 表面处理: 镀金, 导电润滑脂
- 额定电流: 16A
- 接触电阻: $\leq 1m\Omega$
- 工作温度范围: $-40^{\circ}C \dots +125^{\circ}C$
- 线径范围: $0.14-4.0mm^2 (26-12 AWG)$
- 可插拔次数: ≥ 5000

Technical specification:

- Material: copper alloy, conductive grease
- Surface: hard-gold plated
- Rated current: 16A
- Contact resistance: $\leq 1m\Omega$
- Limiting temperatures: $-40^{\circ}C \dots +125^{\circ}C$
- Wire gauge: $0.14-4.0mm^2 (26-12 AWG)$
- Mating cycles: ≥ 5000

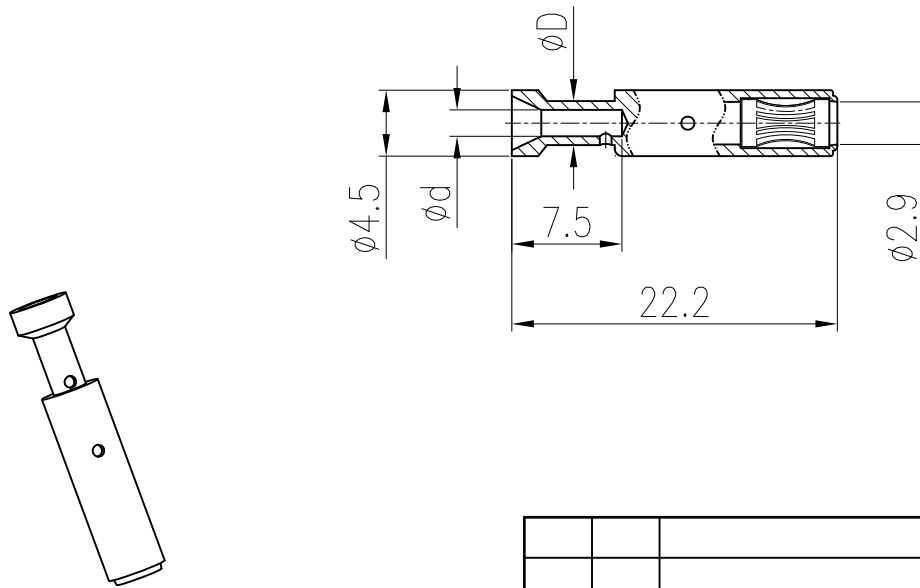

						表面处理 Finish		-		图号 Drawing No.		-	
						材料 Material		-		产品代号 Part Code		CEGFH-XXG	
标记 Mark		处数 Number		变更描述/Description		签名 Signature		日期 Date		产品料号 Part No.		-	
绘图 Drawn		姓名/Name		日期/Date		姓名/Name		日期/Date		比例 Scale		版本 REV.	
审核 Checked		TC CHEN		30.01.2015		-		-		重量 Weight		数量 Qty.	
工艺 Process		-		-		批准 Approved		YY LUO		30.01.2015		-	
										All Dimensions in mm Original Size DIN A 4		厦门唯恩电气有限公司 XIAMEN WAIN ELECTRICAL CO.LTD	